



space ventilation

# Breath Easy

high efficiency heat recovery ventilation from Ubbink

## HR Grande



The HR Grande provides effective heat recovery ventilation to improve indoor air quality throughout larger houses and protect the fabric of the building. Its two EC/DC motors and sophisticated electronic controls ensure high performance with constant air flow and quiet efficient operation.

### Energy positive ventilation

The HR Grande uses a heat exchanger to recover up to 95%\* of the heat from the exhaust air and return it to the supply air. This helps to minimise the difference in temperature between the internal environment and the incoming air, reducing energy loss.

### Operation

The HR Grande is powered by two vibration-free low noise EC/DC motors for quiet and cost-effective operation. It has three variable speed settings which can be adjusted from the control panel. The selected

speeds can be easily controlled using the three speed switch. The standard three speed switch includes a filter change and fault indicator. The HR Grande can also be used with a range of sensors available from Ubbink, including humidistats, timers and PIR detectors.

The incoming air is filtered to reduce pollen and dust and the outgoing air is filtered to protect the heat exchanger. The HR Grande has an integral condensate drain for the safe and effective removal of condensation.

# Breath Easy

high efficiency heat recovery ventilation from Ubbink

## Installation and maintenance

The HR Grande can be easily installed into lofts, cupboards or utility rooms, and wall-mounted using the brackets supplied. The constant velocity DC motors mean that it is not necessary to balance the incoming and outgoing air volumes as the unit automatically sets this balance. Low-resistance ducting, available from Ubbink, should be used to minimise power consumption. Very little maintenance is required: simply remove and clean the filters every two months or as necessary. The filters should be replaced annually and the heat exchanger cleaned every three years. If installed in a cold loft the unit should be enclosed in a thermal jacket and all ducting should be insulated.

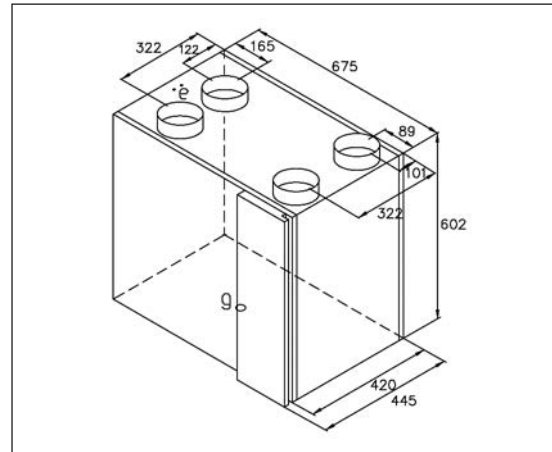

HRV Grande dimensions (mm)

## Options

A summer by-pass option is available, so fresh filtered air can be introduced without being heated.

Specification			
	High	Medium	Low
Air flow rate (m <sup>3</sup> /h) factory default settings	325	200	100
Sound power level (dB[A]):			
Break out	54	46	34
Extract air duct	47	40	32
Supply air duct	69	62	52
Power consumption (W)	132-175	55-67	21-23
Material	Powder-coated steel casing		
Colour	Cream and blue/red		
Weight (kg)	32		
Maximum air flow rate setting	400m <sup>3</sup> /h		
Maximum duct resistance	150pa at 400m <sup>3</sup> /h		

\* Measured in accordance with Netherlands standard NEN 5128 at the output and input points of the heat recovery unit. The amount of heat recovered from the exhaust air depends on a number of factors including the air flow rate, the volume of water vapour in the air and resistance in the system and the temperature of the return air will also depend on duct runs and the level of insulation. As a general guide in normal operating conditions a high efficiency heat recovery system achieving 95% under NEN 5128 would be expected to recover a minimum of 80% of the heat from the exhaust air.

Ubbink - experts in ventilation and heating solutions



Ubbink (UK) Limited

Borough Road, Brackley, Northants NN13 7TB

Tel: 0845 456 3499, Fax: 01280 705332, Email: info@ubpink.co.uk, www.ubpink.co.uk